

MAXINE

# Passive Heave Compensator

Hoisting and lowering a load under maritime conditions entails dealing with peak forces stemming from the oscillations of the waves. This challenge has prompted us to design the MaXine, a new passive heave compensationsystem.

MaXine reduces peak forces and fluctuations during lifting and lowering operations where waves are generating oscillating movements. This allows you to work longer at high sea states, minimise your downtime and extend your weather window. MaXine keeps the rope taut at all times and reduces both the peaks and troughs by following the motion of the sea. This allows work to proceed safely, efficiently and in a controlled manner.

As standard, MaXine carries approval from Lloyd's Register of Shipping, but approval from any other classification organisation can be supplied.

MaXine is available for use worldwide and there is no need for special lifting frames to be installed. The MaXine system is positioned between the hook of the crane and the load, and can also be used underwater. It operates as a stand-alone system, eliminating the need for an external power source.

**MAXINE**



## Passive Heave Compensator

### Maxine

MaXine can be equipped for dynamic loads varying from 25 up to 500 metric tonnes. Other load limits are available on request.

Max. dynamic load (mT)	Max. static load (mT)	Stroke (mm)	Weight (tonnes)
25	30	3000	2.0
50	60	3000	2.5
100	120	3000	5.0
200	240	3000	7.5
500	600	3000	10.0

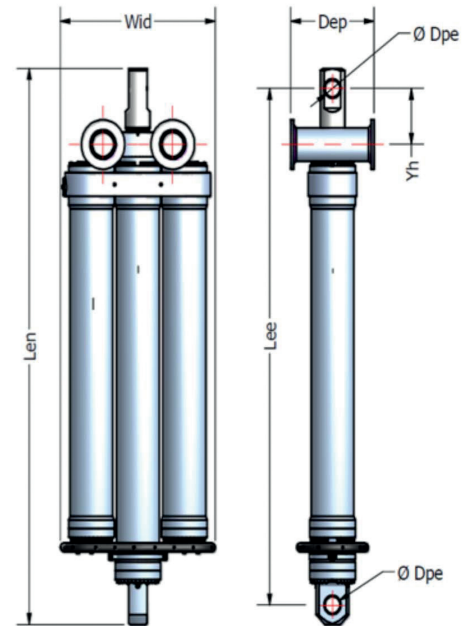

Size [mT] (stroke 3000 mm)	Length (mm)	Width (mm)	Depth (mm)	Diameter pin (mm)	Yoke height (mm)	Length C.t.C. (mm)
	Len	Wid	Dep	Dpe	Yh	Lee
25	3975	880	440	70	260	3820
50	4055	1010	500	85	240	3835
100	4325	1300	540	110	355	4055
200	5055	1600	860	155	509	4695
500	5630	2310	1280	220	614	5110

- For use both above water and underwater
- No external power required
- Reduces costs by enabling you to work longer at high sea states
- No special lifting frames required

### Additional options available for MaXine

- Load Increase Option via a tandem assembly
- Enabling functionality or start/stop functionality
- Quick lift option
- Yoke reduces building-in length
- Longer strokes for underwater operations

**Boosting your motion & control**

Vremac Cylinders BV

Oude Apeldoornseweg 33J

7333 NR Apeldoorn

The Netherlands

+31 85 079 7800

info@vremac.com

www.vremac.com